

◀ VIDEO DOORPHONE

■ Handset monitors:

MT210B-CK2U MT210C-7CK2U MT200B/C-CK2
 MT210B-CK2 MT210C-7CK2

■ Hands-free monitors:

MT320C-CK2 MT333C-CK2 MT18B/C-CK2
 MT37XC-CK2U MT37XC-CK2 MT181B/C-CK2
 MT350C-CK2 MT360C-CK2 MT360T-CK2
 MT361C-CK2 MT361T-CK2 MT300C-CK2
 MT8T-CK2

No.	Icon	Description	No.	Icon	Description
①		Microphone	⑧	☀	Brightness
②	📺	Monitor	⑨	🗨️	Chroma/contrast
③	🚪	Door unlocked	⑩		System terminal
④	🗣️	Talking	⑪	📞	Calling
⑤		TFT display/CRT	⑫		Handset
⑥		Speaker	⑬		Indicated light
⑦	🔊	Talking volume	⑭	🔔	Ringling volume

CAUTION:

1. When connect with more than one indoor monitor, please connect with the J2 of the farthest indoor monitor, and disconnect the J2 of the rest of the indoor monitors.
2. When connect with more than one indoor monitor, please connect with the J1 and J3 of the closest indoor monitor, and disconnect the J1 and J3 of the rest of the indoor monitors.

■ Handset monitor: MT8T-CK2

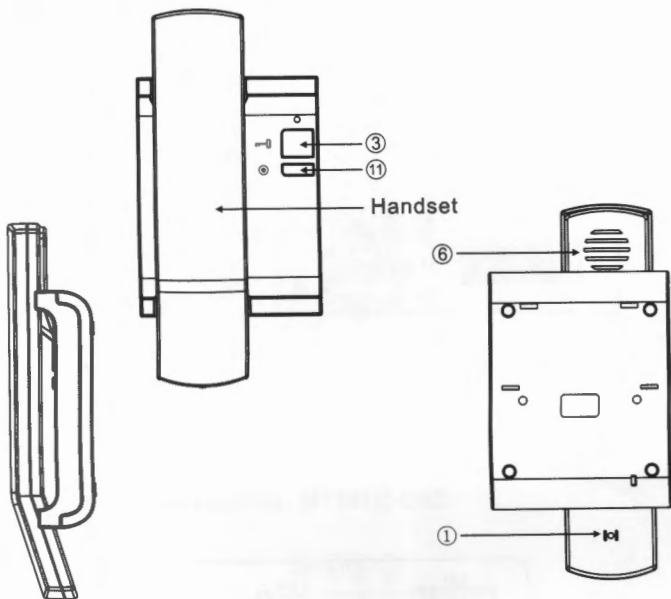

Dimension: 198x95x45mm



Short circuit J3:
Night light of
outdoor station
Short circuit J1:
Ringing output



Connected with
outdoor station1



Connected with
outdoor station2

1.red 2.blue 3.yellow 4.white 5.red 6.black
1-AUDIO 2-GND 3-V+ 4-VIDEO
5-POWER+ 6-POWER GND

Wiring for Classic Video Intercoms

For the INDOOR MONITORS the 4 wires are:

- 1 = Blue = Audio
- 2 = Black = Ground (or negative)
- 3 = Red = positive (V+)
- 4 = Yellow = Video

For the OUTDOOR CAMERAS (see below) the 4 wires are

- 1 = Red = Audio
- 2 = Blue = Ground (or negative)
- 3 = Yellow = positive (V+)
- 4 = White = Video

For the AUDIO HANDSET the 4 wires are:

- 1 = Red = Audio
- 2 = Blue = Ground (or negative)
- 3 = Yellow = positive (V+)
- 4 = White = Video

Connect 1:1, 2:2, 3:3, 4:4, using CN1 on the monitor for the 1st outdoor station and CN2 for the 2nd outdoor station.

Do NOT match the colours, match the numbers.

Each monitor requires its own power from the plug pack supplied.

It may be necessary to extend the lead on the plug pack with figure 8 cable.

The outdoor cameras with this colour wiring are:

- VDP4-5CK
- VDP4-35CK
- VDP4-50CK
- VDP4-551CK
- VDP4-561CK

Other outdoor cameras have the same colour wiring as in the indoor monitors

- VDP4-961CR